

K-SERIES COMPACT LOADERS

204K/304K



JOHN DEERE





Make short work of your next material-moving task.

When your work requires a compact loader to get the task done, choose a 204K or 304K. Serious breakout force and solid full-turn tipping load capacities make these small-but-mighty machines plenty productive. With a top speed of 20 km/h (12 mph), 930-mm (3 ft. 1 in.) reach, and 2.62-m (8 ft. 7 in.) lift height, they're an attractive alternative to skid steers for loading trucks or placing pallets on trailers. Get yours with an open canopy for quick and easy entrance/exit. Or opt for an air-conditioned/heated cab and enjoy year-round comfort and ability. Standard skid-steer-style quick-coupler and auxiliary hydraulics, plus numerous compatible Worksite Pro™ attachments, further add to their do-it-all flexibility.



Specifications	204K	304K
Net Rated Power	44 kW (59 hp)	48 kW (64 hp)
Full-Turn Tipping Load	3280 kg (7,231 lb.)	3670 kg (8,091 lb.)
Bucket Breakout Force	4170 kg (9,190 lb.)	5370 kg (11,839 lb.)
Operating Weight	5355 kg (11,806 lb.)	5796 kg (12,778 lb.)
Height to Top of Cab	2.45 m (7 ft. 11 in.)	2.47 m (8 ft. 0 in.)
Height to Hinge Pin	3.18 m (10 ft. 5 in.)	3.37 m (11 ft. 1 in.)

1. Low center of gravity and exceptional balance yield impressive stability and full-turn tipping-load capacities.
2. Elastic articulation at the pivot point smooths the ride for greater load retention and reduced operator fatigue.
3. Limited-slip differential lock automatically delivers the power to the tire with the best traction for extra bucket-filling effort.
4. Tapered lift arms and single boom and bucket cylinders enhance visibility without sacrificing breakout force.



Just 2.47-m (8 ft.) tall, our K-Series Compacts deliver lower clearance than many wheel loaders in their class — and are a full foot lower than our 244J.

Precise parallel control over the entire lift range helps ease material handling.





The lowdown on high productivity.

Whether you use them for shuttling seed, heaping hoppers, loading landscape materials, or whatever — these low-profile compacts navigate with ease through low entryways and narrow openings. Articulated steering delivers a tight turn radius for excellent close-quarters maneuverability and fast work cycles. When the task takes you over rough terrain, their oscillating front loader frames absorb pitching motion and reduce cab tilt for a stable and comfortable ride.

Purpose built for a variety of purposes.

Generally speaking, every operator prefers a cab. But not every operation profits from having one. That's the beauty of our compacts. You can get yours equipped with or without. Unlike the canopies on other loaders that are little more than cabs with the glass removed, ours are designed to withstand the elements — with weather-resistant gauges, extended rooftops, nonskid floor mats, and optional vandal proofing. For year-round comfort and ability, equip yours with an optional heated and air-conditioned cab. Either way, controls are ergonomically designed and within easy reach. A single lever with FNR switch controls all boom, bucket, and travel functions, for simple and efficient machine operation.

Air-conditioned low-profile cab provides year-round comfort and foul-weather material handling or snow removal.

Fingertip control of the coupler, travel speed, park brake, lights, and other machine functions are close and convenient.

Expansive curved tinted glass and narrow corner posts enhance visibility.

Optional creeper control allows slow incremental travel speeds while maintaining full hydraulic flow. It's ideal for hydraulic-driven attachments such as brooms.



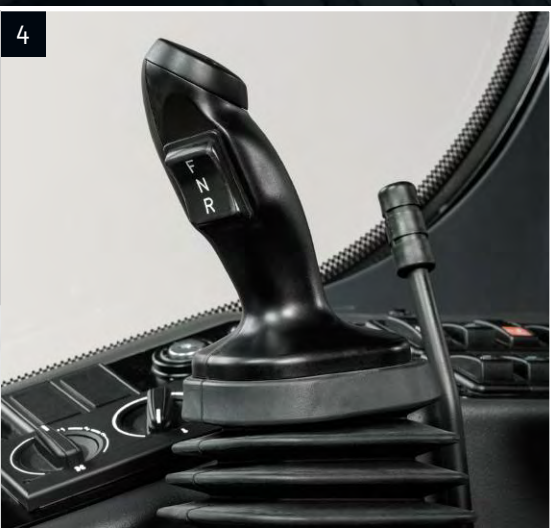

1. ROPS-certified open-canopy models are perfect for applications requiring the operator to frequently get on and off the machine.

2. Easy-to-read monitor displays engine, cooling, and hydraulic system status, as well as numerous operational settings.

3. Optional lockable monitor and switch covers provide after-hours security and vandal protection.

4. Boom, bucket, and F-N-R are on the same ergonomic low-effort lever for convenient one-hand control.

Work your connections.

With standard quick-coupler and auxiliary hydraulics, the 204K and 304K let you easily connect to numerous attachments. Going from bucket to forks to whatever is pushbutton easy. What's more, several Worksite Pro attachments are compatible with our skid steers, compact track loaders, and 244J Loader. So you can maximize utilization and make the most of your investment.

1. The pushbutton-actuated skid-steer-style coupler lets an operator attach and release attachments quickly from the seat. What's more, the coupler doesn't require special adapters that reduce bucket breakout or rollback.

2. Pickup brooms let you sweep up dust and debris, and haul it away or deposit it in a dumpster.

3. Blades, buckets, and pushers make these loaders natural for removing whatever winter drops your way.

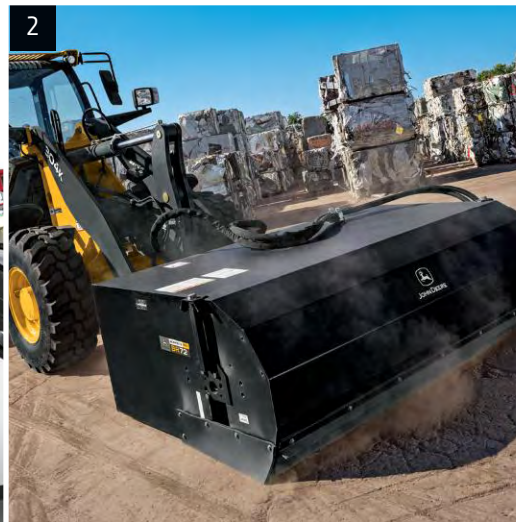
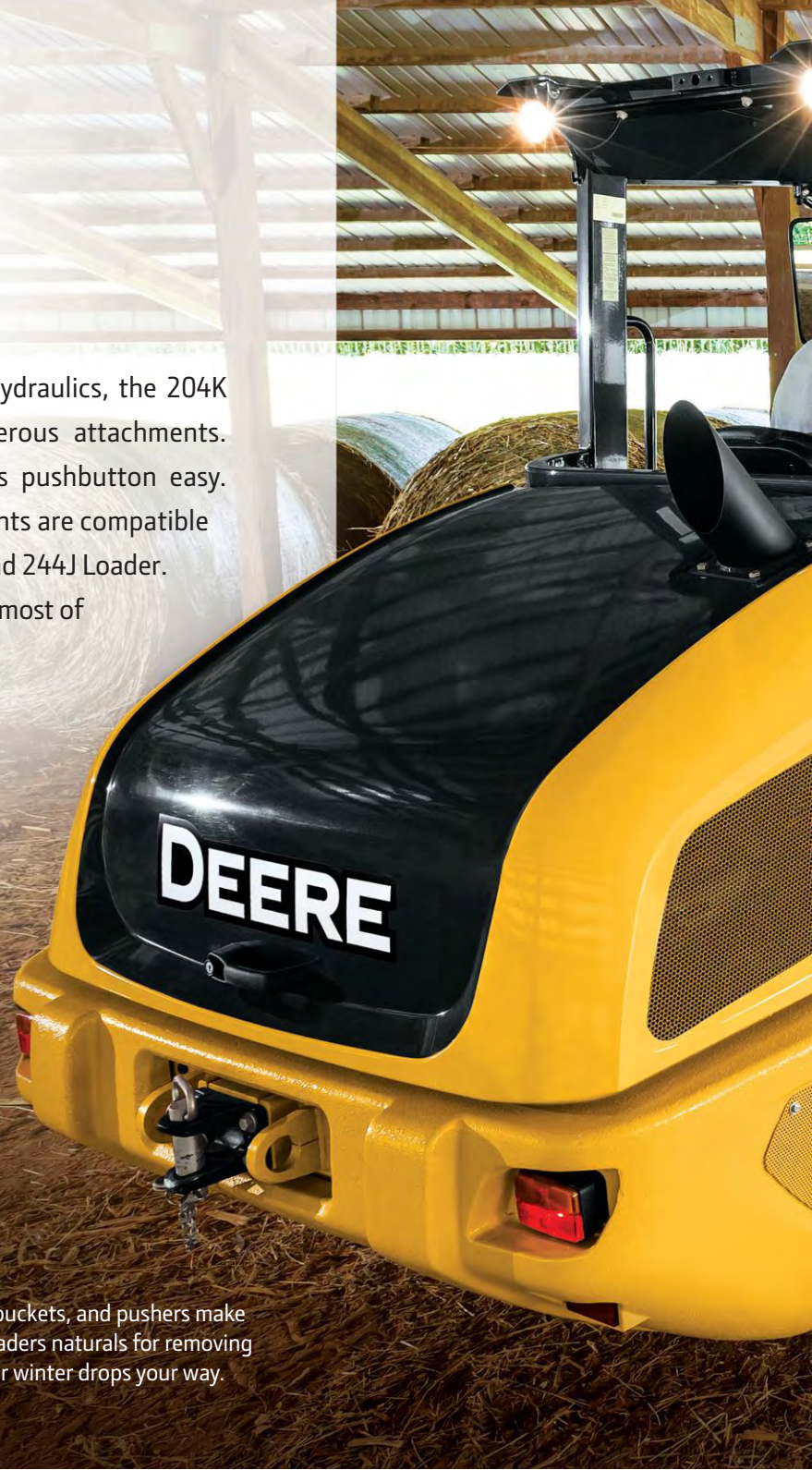



4. For moving mulch, shuttling sand, or carving through clay, we've got the right bucket for the job. Capacities range from 0.8 to 1.6 m³ (1.0 to 2.1 cu. yd.).

5. Like their green-and-yellow siblings, these loaders are right at home on the farm. Equipped with bale spear, forks, or bucket, these highly maneuverable machines handle a multitude of chores.

6. Scrap grapples let you move a variety of materials — from bales to branches. Two hydraulic-actuated dual-action tongs provide firm material retention.



Daily servicing is quick and convenient. Transverse-mounted engine provides convenient access to dipsticks and filler necks.

Field-proven ultra-reliable diesels meet EPA Interim Tier 4 (IT4)/EU Stage IIIA regulations without aftertreatment devices.

Inboard park and service brakes are sealed and self-adjust for long-term maintenance-free performance.

Ultra-reliable electrical system minimizes the number of wires, mechanical relays, and unsealed connections for maximum durability and uptime.



Keep daily operating costs low, too.

With these loaders, low overhead also applies to maintenance. Their lockable easy-open tilting hoods provide convenient, ground-level access to daily checkpoints, as well as periodic service items such as fluids and filters. What's more, environmentally friendly drains, extended service intervals, and sight gauges help keep upkeep simple and inexpensive. Should parts or service be required, they're readily available at more than 1,300 John Deere dealer locations from coast to coast.

1. Easy-access vertical filters and environmental drains make fluid changes quick and clean.
2. Convenient maintenance and lube chart helps ensure that nothing gets overlooked.
3. Cooler cores are easily accessible for quick clean-out. Engine-mounted belt-driven cooling fan delivers efficient, reliable performance.
4. Ground-level fuel fill and see-through coolant reservoir are close and convenient to help simplify daily servicing.

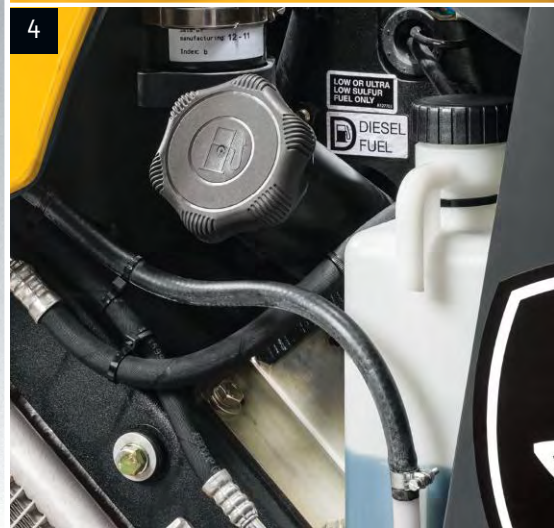

204K



Engine	204K
Manufacturer and Model	Yanmar 4TNV98
Non-Road Emission Standard	EPA Interim Tier 4/EU Stage IIIA
Cylinders	4
Valves Per Cylinder	4
Displacement	3.3 L (203 cu. in.)
Net Rated Power at 2,200 rpm (ISO 9249)	44 kW (59 hp)
Maximum Net Torque at 1,600 rpm (ISO 9249)	239 Nm (176 lb.-ft.)
Gross Rated Power at 2,200 rpm	46 kW (62 hp)
Engine Bore and Stroke	98 x 110 mm (3.89 x 4.33 in.)
Lubrication	Pressure system with full-flow spin-on filter
Fuel System	Electronically controlled unit-injection pump
Aspiration	Naturally aspirated
Air Cleaner	Dual safety element dry type
Cooling	
Fan	Direct driven
Engine Coolant Rating	-37 deg. C (-34 deg. F)
Hydraulic Oil Cooling	Oil to air
Powertrain	
Type	Hydrostatic (HST) with infinitely variable speed control over full range of operating speeds; 2 speed ranges; joystick-mounted F-N-R; acceleration pedal; HST inching pedal, which allows infinitely reduced travel speeds while maintaining full engine rpm and hydraulic flow
2 Travel Speeds in Forward and Reverse (equipped with 365/70R18 tires)	
Gear 1	6 km/h (3.7 mph)
Gear 2	20 km/h (12.0 mph)
Axles	Rigid-mount front and rear axles with 10-deg. frame oscillation
Rear Axle Oscillation Versus Front Axle	20 deg. total, stop to stop
Differentials	45% locking front and rear differentials
Maximum Rise and Fall, Single Wheel	254 mm (10 in.)
Steering	Hydraulic power steering (SAE J1511); 40-deg. articulation left and right
Steering Wheel Turns, Stop to Stop	3.5 left to 4.5 right
Articulation Angle	80-deg. arc (40 deg. each direction)
Final Drive	Heavy-duty outboard planetary
Brakes (SAE J1473 and ISO 3450)	
Service Brakes	Hydraulically actuated, self-adjusting internal wet-disc brake and driveline drum brake
Parking Brake	Automatically spring-applied, hydraulically released, internal wet disc
Hydraulics	
Main Pump (loader and steering)	Fixed-displacement gear pump; open-center system
Rated rpm	2,200
Maximum Rated Flow at 6895 kPa (1,000 psi)	70 L/m (18 gpm)
System Relief Pressure	
Loader	23 000 kPa (3,335 psi)
Steering	18 002 kPa (2,611 psi)



Hydraulics (continued)	204K		
Hydraulic Cycle Times			
Raise	5.6 sec.		
Dump	1.5 sec.		
Lower			
Float Down	4.7 sec.		
Power Down	4.3 sec.		
Total	11.4 sec.		
Maximum Lift Capacity	<i>With 0.8-m³ (1.0 cu. yd.) Quik-Tatch™ bucket with bolt-on cutting edge</i>		
Lift at Ground Level	4175 kg (9,204 lb.)		
Lift at Maximum Height	3700 kg (8,157 lb.)		
Turning Radius			
Measured to Centerline of Outside Tire	3.9 m (12 ft. 10 in.)		
Controls			
Pilot-operated, 3-function valve with single-lever control for boom and bucket, and auxiliary level for auxiliary hydraulics, with control-lever lockout feature			
Cylinders			
Type	Heat-treated, chrome-plated, polished cylinder rods; hardened steel (replaceable bushings) pivot pins		
Electrical			
Type	Electrical load center with blade-type multi-fused circuits		
Voltage	12 volt		
Number of Batteries	1		
Battery Capacity	850 CCA		
Reserve Capacity	80 min.		
Alternator Rating	80 amp		
Lights (SAE 99)	Driving/front working lights (2), rear working lights (2), turn signals, flashers, and stop- and taillights		
Tires/Wheels			
Tires on Single-Piece Rims	<i>Tread Width</i>	<i>Width Over Tires</i>	<i>Change In Vertical Height</i>
365/70R18 Dunlop SPT9 (standard)	1387 mm (54.6 in.)	1750 mm (69.9 in.)	0 mm (0 in.)
400/70R20 Michelin XMCL (optional)	1376 mm (54.2 in.)	1790 mm (70.5 in.)	+ 29 mm (+ 1.1 in.)
405/70R18 Firestone DuraForce (optional)	1427 mm (56.2 in.)	1790 mm (70.5 in.)	+ 8 mm (+ 0.3 in.)
365/70R18 Mitas EM-01 (optional)	1397 mm (55.0 in.)	1760 mm (69.3 in.)	- 1 mm (- 0.04 in.)
Serviceability			
Refill Capacities			
Cooling System (engine and radiator)	12 L (12.7 qt.)		
Differential and Planetary Axle (front and rear)	6 L (6.4 qt.)		
Engine Oil with Filter	10 L (10.8 qt.)		
Fuel Tank	50 L (13.2 gal.)		
Hydraulic/Hydrostatic Reservoir with Filter	90 L (23.8 gal.)		
Hydrostatic Motor Gearbox	1 L (1.1 qt.)		
Operating Weights			
With standard equipment, 365/70R18 tires, standard counterweight, cab, 79-kg (175 lb.) operator, and full fuel tank			
With Quick-Coupler and 0.8-m ³ (1.0 cu. yd.) Stockpiling/General-Purpose Bucket with Bolt-On Edge	5355 kg (11,806 lb.)		
With Quick-Coupler and 1.1-m ³ (1.4 cu. yd.) Stockpiling/General-Purpose Bucket with Bolt-On Edge	5465 kg (12,048 lb.)		
Loader with Quick-Coupler and Fork	5004 kg (11,032 lb.)		
Optional Components			
0.8-m ³ (1.0 cu. yd.) Bucket	535 kg (1,179 lb.)		
1.1-m ³ (1.4 cu. yd.) Bucket	645 kg (1,421 lb.)		
1.22-m (48 in.)-Tine Fork	184 kg (407 lb.)		

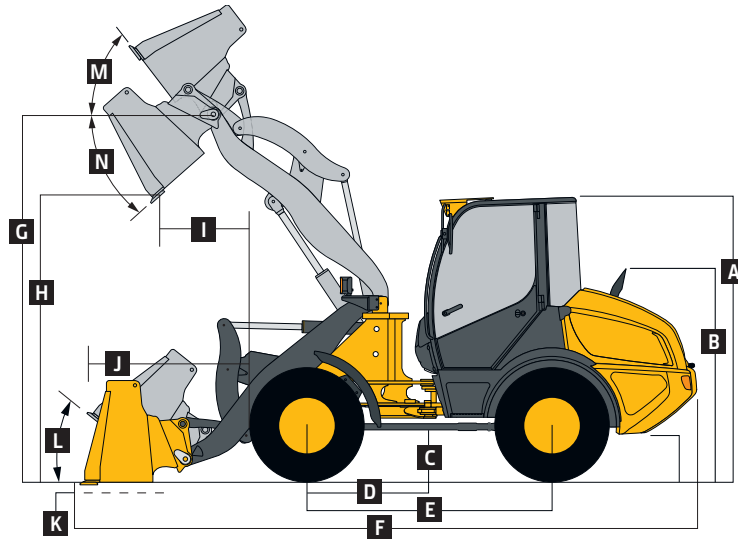

Dimensions with Quick-Coupler and Bucket

0.8-m³ (1.0 cu. yd.) stockpiling/
general purpose with bolt-on edge

1.1-m³ (1.4 cu. yd.) stockpiling/
general purpose with bolt-on edge

A	Height to Top of Cab	2.45 m (7 ft. 11 in.)	2.45 m (7 ft. 11 in.)
B	Height to Top of Exhaust	1.80 m (5 ft. 11 in.)	1.80 m (5 ft. 11 in.)
C	Ground Clearance	318 mm (12.5 in.)	318 mm (12.5 in.)
D	Length from Centerline to Front Axle	1067 mm (3 ft. 6 in.)	1067 mm (3 ft. 6 in.)
E	Wheelbase	2.15 m (7 ft. 1 in.)	2.15 m (7 ft. 1 in.)
F	Overall Length, Bucket on Ground	5.42 m (17 ft. 4 in.)	5.46 m (17 ft. 11 in.)
G	Height to Hinge Pin, Fully Raised	3.18 m (10 ft. 5 in.)	3.18 m (10 ft. 5 in.)
H	Dump Clearance, 40-deg. Full Height	2.43 m (8 ft. 0 in.)	2.38 m (7 ft. 9 in.)
I	Reach, 40-deg. Dump, Full Height	920 mm (3 ft. 0 in.)	968 mm (3 ft. 2 in.)
J	Maximum Dump Reach, 42 deg.	1.49 m (4 ft. 11 in.)	1.54 m (3 ft. 11 in.)
K	Maximum Digging Depth	70 mm (2.8 in.)	70 mm (2.8 in.)
L	Maximum Rollback at Ground Level	37 deg.	37 deg.
M	Maximum Rollback at Full Height	65 deg.	65 deg.
N	Maximum Bucket Dump Angle, Fully Raised	40 deg.	40 deg.

Specifications with Quick-Coupler and Bucket

Capacity, Heaped	0.8 m ³ (1.0 cu. yd.)	1.1 m ³ (1.4 cu. yd.)
Capacity, Struck	0.66 m ³ (0.86 cu. yd.)	0.90 m ³ (1.18 cu. yd.)
Bucket Width	1.90 m (6 ft. 3 in.)	2.20 m (7 ft. 3 in.)
Breakout Force	4170 kg (9,190 lb.)	3770 kg (8,311 lb.)
Tipping Load, Straight	3700 kg (8,157 lb.)	3550 kg (7,826 lb.)
Tipping Load, Full Turn	3280 kg (7,231 lb.)	3130 kg (6,900 lb.)
Rated Operating Load, 50% of Full-Turn Tipping Load (conforms to ISO 14397-1)*	1640 kg (3,616 lb.)	1565 kg (3,450 lb.)
Loader Clearance Circle, Bucket Carry Position	8.46 m (27 ft. 9 in.)	8.59 m (28 ft. 2 in.)

*Rated operating capacity based on Deere attachments only.

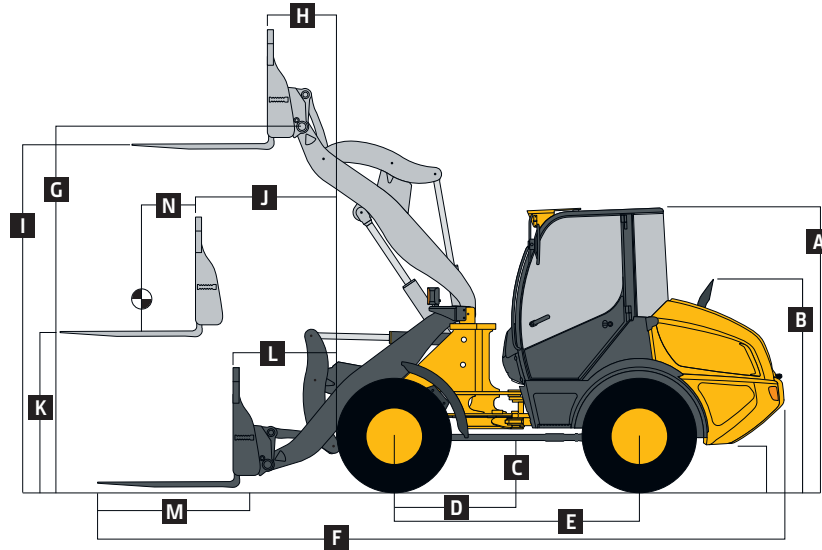

Dimensions with Quick-Coupler and Fork 1.22-m (48 in.) tine length

A	Height to Top of Cab	2.45 m (7 ft. 11 in.)
B	Height to Top of Exhaust	1.80 m (5 ft. 11 in.)
C	Ground Clearance	318 mm (12.5 in.)
D	Length from Centerline to Front Axle	1067 mm (3 ft. 6 in.)
E	Wheelbase	2.15 m (7 ft. 1 in.)
F	Overall Length, Forks on Ground	5.92 m (19 ft. 5 in.)
G	Height to Hinge Pin, Fully Raised	3.18 m (10 ft. 5 in.)
H	Reach, Fully Raised	450 mm (18 in.)
I	Fork Height, Fully Raised	3.00 m (9 ft. 10 in.)
J	Maximum Reach, Fork Level	1.22 m (4 ft. 0 in.)
K	Fork Height, Maximum Reach	1.37 m (4 ft. 6 in.)
L	Reach, Ground Level	780 mm (31 in.)
M	Tine Length	1.22 m (48 in.)
N	Load Position, 50% Tine Length	0.61 m (24 in.)

Specifications with Fork As measured with fork level, centered on tine

Tipping Load, Straight	2568 kg (5,661 lb.)
Tipping Load, 40-deg. Full Turn	1541 kg (3,397 lb.)
Rated Operating Load, 50% Full-Turn Tipping Load (conforms to ISO 14397-1 and SAE J1197)*	771 kg (1,699 lb.)
Rated Operating Load, Rough Terrain, 60% Full-Turn Tipping Load (conforms to EN474-3)*	925 kg (2,038 lb.)
Rated Operating Load, Firm and Level Ground, 80% Full-Turn Tipping Load (conforms to EN474-3)*	1233 kg (2,718 lb.)

*Rated operating capacity based on Deere attachments only.

Bucket Selection Guide*

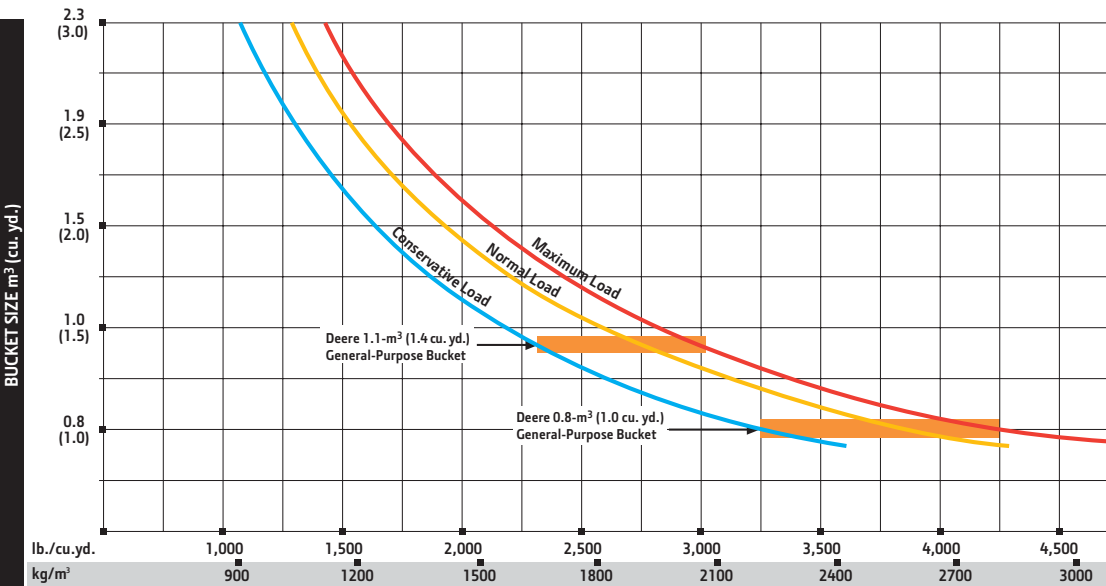

LOOSE MATERIALS	kg/m³	lb./cu. yd.
Chips, pulpwood	288	486
Cinders (coal, ashes, clinkers)	673	1,134
Clay and gravel, dry	1602	2,700
Clay, compact, solid	1746	2,943
Clay, dry in lump loose	1009	1,701
Clay, excavated in water	1282	2,160
Coal, anthracite, broken, loose	865	1,458
Coal, bituminous, moderately wet	801	1,350
Earth, common loam, dry	1218	2,052
Earth, mud, packed	1843	3,105
Granite, broken	1538	2,592
Gypsum	2275	3,834
Limestone, coarse, sized	1570	2,646
Limestone, mixed sizes	1682	2,835
Limestone, pulverized or crushed	1362	2,295
Sand, damp	2083	3,510
Sand, dry	1762	2,970
Sand, voids, full of water	2083	3,510
Sandstone, quarried	1314	2,214
Shale, broken crushed	1362	2,295
Slag, furnace granulated	1955	3,294
Stone or gravel, 37.5 to 87.5-mm (1.5 to 3.5") size	1442	2,430
Stone or gravel, 18.75-mm (3/4") size	1602	2,700

*This guide, representing bucket sizes not necessarily manufactured by Deere, will help you in selecting proper bucket size for material density, loader configuration, and operating conditions. Optimum bucket size is determined after adding or subtracting all tipping load changes due to optional equipment. The "conservative load" line on this guide is recommended when operating in conditions such as soft ground and unlevel surfaces. The "maximum load" condition on this guide is sometimes utilized when operating on firm ground and level surfaces.

304K

Engine	304K
Manufacturer and Model	Yanmar 4TNV98
Non-Road Emission Standard	EPA Interim Tier 4/EU Stage IIIA
Cylinders	4
Valves Per Cylinder	4
Displacement	3.3 L (203 cu. in.)
Net Rated Power at 2,400 rpm (ISO 9249)	48 kW (64 hp)
Maximum Net Torque at 1,600 rpm (ISO 9249)	239 Nm (176 lb.-ft.)
Gross Rated Power at 2,400 rpm	50 kW (67 hp)
Engine Bore and Stroke	98 x 110 mm (3.89 x 4.33 in.)
Lubrication	Pressure system with full-flow spin-on filter
Fuel System	Electronically controlled unit-injection pump
Aspiration	Naturally aspirated
Air Cleaner	Dual safety element dry type
Cooling	
Fan	Direct driven
Engine Coolant Rating	-37 deg. C (-34 deg. F)
Hydraulic Oil Cooling	Oil to air
Powertrain	
Type	Hydrostatic (HST) with infinitely variable speed control over full range of operating speeds; 2 speed ranges; joystick-mounted F-N-R; acceleration pedal; HST inching pedal, which allows infinitely reduced travel speeds while maintaining full engine rpm and hydraulic flow
2 Travel Speeds in Forward and Reverse (equipped with 365/70R18 tires)	
Gear 1	6 km/h (3.7 mph)
Gear 2	20 km/h (12.0 mph)
Axles	Rigid-mount front and rear axles with 10-deg. frame oscillation
Rear Axle Oscillation Versus Front Axle	20 deg. total, stop to stop
Differentials	45% locking front and rear differentials
Maximum Rise and Fall, Single Wheel	254 mm (10 in.)
Steering	Hydraulic power steering (SAE J1511); 40-deg. articulation left and right
Steering Wheel Turns, Stop to Stop	3.5 left to 4.5 right
Articulation Angle	80-deg. arc (40 deg. each direction)
Final Drive	Heavy-duty outboard planetary
Brakes (SAE J1473 and ISO 3450)	
Service Brakes	Hydraulically actuated, self-adjusting internal wet-disc brake and driveline drum brake
Parking Brake	Automatically spring-applied, hydraulically released, internal wet disc
Hydraulics	
Main Pump (loader and steering)	Fixed-displacement gear pump; open-center system
Rated rpm	2,400
Maximum Rated Flow at 6895 kPa (1,000 psi)	77 L/m (20 gpm)
System Relief Pressure	
Loader	23 000 kPa (3,335 psi)
Steering	18 002 kPa (2,611 psi)



Hydraulics (continued)		304K	
Hydraulic Cycle Times			
Raise		6.6 sec.	
Dump		1.6 sec.	
Lower			
Float Down		5.7 sec.	
Power Down		5.3 sec.	
Total		13.5 sec.	
Maximum Lift Capacity		<i>With 1.1-m³ (1.4 cu. yd.) Quik-Tatch™ bucket with bolt-on cutting edge</i>	
Lift at Ground Level		5590 kg (12,324 lb.)	
Lift at Maximum Height		4550 kg (10,031 lb.)	
Turning Radius			
Measured to Centerline of Outside Tire		3.9 m (12 ft. 10 in.)	
Controls			
Pilot-operated, 3-function valve with single-lever control for boom and bucket, and auxiliary level for auxiliary hydraulics, with control-lever lockout feature			
Cylinders			
Type		Heat-treated, chrome-plated, polished cylinder rods; hardened steel (replaceable bushings) pivot pins	
Electrical			
Type		Electrical load center with blade-type multi-fused circuits	
Voltage		12 volt	
Number of Batteries		1	
Battery Capacity		850 CCA	
Reserve Capacity		80 min.	
Alternator Rating		80 amp	
Lights (SAE 99)		Driving/front working lights (2), rear working lights (2), turn signals, flashers, and stop- and taillights	
Tires/Wheels			
Tires on Single-Piece Rims	<i>Tread Width</i>	<i>Width Over Tires</i>	<i>Change In Vertical Height</i>
405/70R18 Dunlop SPT9 (standard)	1417 mm (55.8 in.)	1780 mm (70.1 in.)	0 mm (0 in.)
400/70R20 Michelin XMCL (optional)	1376 mm (54.2 in.)	1790 mm (70.5 in.)	+ 19 mm (+ 0.7 in.)
405/70R18 Firestone DuraForce (optional)	1427 mm (56.2 in.)	1790 mm (70.5 in.)	- 1 mm (- 0.04 in.)
405/70R20 Mitas EM-01 (optional)	1376 mm (54.2 in.)	1790 mm (70.5 in.)	- 1 mm (- 0.04 in.)
Serviceability			
Refill Capacities			
Cooling System (engine and radiator)		12 L (12.7 qt.)	
Differential and Planetary Axle (front and rear)		6 L (6.4 qt.)	
Engine Oil with Filter		10 L (10.8 qt.)	
Fuel Tank		50 L (13.2 gal.)	
Hydraulic/Hydrostatic Reservoir with Filter		90 L (23.8 gal.)	
Hydrostatic Motor Gearbox		1 L (1.1 qt.)	
Operating Weights			
With standard equipment, 405/70R18 tires, standard counterweight, cab, 79-kg (175 lb.) operator, and full fuel tank			
With Quick-Coupler and 0.8-m ³ (1.0 cu. yd.) Stockpiling/ General-Purpose Bucket with Bolt-On Edge		5796 kg (12,778 lb.)	
With Quick-Coupler and 1.1-m ³ (1.4 cu. yd.) Stockpiling/ General-Purpose Bucket with Bolt-On Edge		5906 kg (13,021 lb.)	
With Quick-Coupler and 1.6-m ³ (2.1 cu. yd.) Light-Material Bucket with Bolt-On Edge		5991 kg (13,208 lb.)	
Loader with Quick-Coupler and Fork		5445 kg (12,004 lb.)	
Optional Components			
0.8-m ³ (1.0 cu. yd.) Bucket		535 kg (1,179 lb.)	
1.1-m ³ (1.4 cu. yd.) Bucket		645 kg (1,421 lb.)	
1.6-m ³ (2.1 cu. yd.) Bucket		730 kg (1,609 lb.)	
1.22-m (48 in.)-Tine Fork		184 kg (407 lb.)	

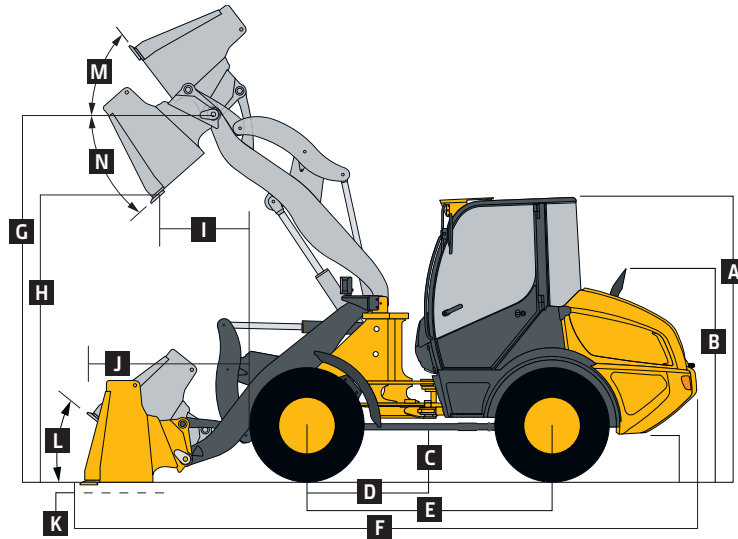

Dimensions with Quick-Coupler and Bucket	0.8-m ³ (1.0 cu. yd.) stockpiling/ general purpose with bolt-on edge	1.1-m ³ (1.4 cu. yd.) stockpiling/ general purpose with bolt-on edge	1.6-m ³ (2.1 cu. yd.) light material with bolt-on edge
A Height to Top of Cab	2.47 m (8 ft. 0 in.)	2.47 m (8 ft. 0 in.)	2.47 m (8 ft. 0 in.)
B Height to Top of Exhaust	1.82 m (5 ft. 11 in.)	1.82 m (5 ft. 11 in.)	1.82 m (5 ft. 11 in.)
C Ground Clearance	330 mm (13 in.)	330 mm (13 in.)	330 mm (13 in.)
D Length from Centerline to Front Axle	1067 mm (3 ft. 6 in.)	1067 mm (3 ft. 6 in.)	1067 mm (3 ft. 6 in.)
E Wheelbase	2.15 m (7 ft. 1 in.)	2.15 m (7 ft. 1 in.)	2.15 m (7 ft. 1 in.)
F Overall Length, Bucket on Ground	5.52 m (18 ft. 1 in.)	5.62 m (18 ft. 5 in.)	5.75 m (18 ft. 10 in.)
G Height to Hinge Pin, Fully Raised	3.37 m (11 ft. 1 in.)	3.37 m (11 ft. 1 in.)	3.37 m (11 ft. 1 in.)
H Dump Clearance, 40-deg. Full Height	2.62 m (8 ft. 7 in.)	2.57 m (8 ft. 5 in.)	2.49 m (8 ft. 2 in.)
I Reach, 40-deg. Dump, Full Height	930 mm (3 ft. 1 in.)	975 mm (3 ft. 2 in.)	1055 mm (3 ft. 5 in.)
J Maximum Dump Reach, 42 deg.	1.60 m (5 ft. 4 in.)	1.65 m (5 ft. 6 in.)	1.69 m (5 ft. 7 in.)
K Maximum Digging Depth	70 mm (2.8 in.)	70 mm (2.8 in.)	70 mm (2.8 in.)
L Maximum Rollback at Ground Level	37 deg.	37 deg.	37 deg.
M Maximum Rollback at Full Height	65 deg.	65 deg.	65 deg.
N Maximum Bucket Dump Angle, Fully Raised	40 deg.	40 deg.	40 deg.
Specifications with Quick-Coupler and Bucket			
Capacity, Heaped	0.8 m ³ (1.0 cu. yd.)	1.1 m ³ (1.4 cu. yd.)	1.6 m ³ (2.1 cu. yd.)
Capacity, Struck	0.66 m ³ (0.86 cu. yd.)	0.90 m ³ (1.18 cu. yd.)	1.40 m ³ (1.80 cu. yd.)
Bucket Width	1.90 m (6 ft. 3 in.)	2.20 m (7 ft. 3 in.)	2.40 m (7 ft. 10 in.)
Breakout Force	5370 kg (11,839 lb.)	4790 kg (10,560 lb.)	4120 kg (9,083 lb.)
Tipping Load, Straight	4000 kg (9,171 lb.)	4000 kg (8,818 lb.)	3800 kg (8,378 lb.)
Tipping Load, 40-deg. Full Turn	3670 kg (8,091 lb.)	3600 kg (7,937 lb.)	3350 kg (7,385 lb.)
Rated Operating Load, 50% of Full-Turn Tipping Load (conforms to ISO 14397-1)*	1835 kg (4,046 lb.)	1800 kg (3,969 lb.)	1675 kg (3,693 lb.)
Loader Clearance Circle, Bucket Carry Position	8.93 m (29 ft. 4 in.)	9.06 m (29 ft. 8 in.)	9.11 m (29 ft. 11 in.)
*Rated operating capacity based on Deere attachments only.			

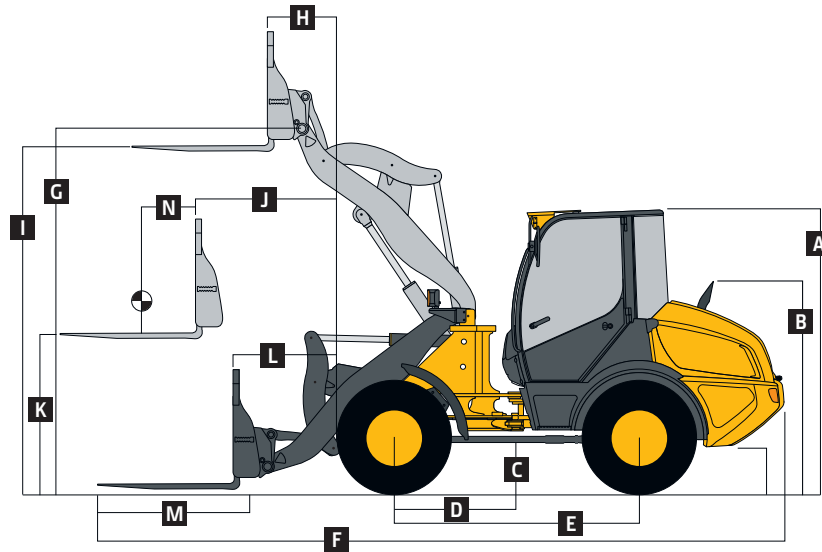

Dimensions with Quick-Coupler and Fork 1.22-m (48 in.) tine length

A	Height to Top of Cab	2.47 m (8 ft. 0 in.)
B	Height to Top of Exhaust	1.82 m (5 ft. 11 in.)
C	Ground Clearance	330 mm (13 in.)
D	Length from Centerline to Front Axle	1067 mm (3 ft. 6 in.)
E	Wheelbase	2.15 m (7 ft. 1 in.)
F	Overall Length, Forks on Ground	5.96 m (19 ft. 7 in.)
G	Height to Hinge Pin, Fully Raised	3.37 m (11 ft. 1 in.)
H	Reach, Fully Raised	515 mm (20 in.)
I	Fork Height, Fully Raised	3.20 m (10 ft. 6 in.)
J	Maximum Reach, Fork Level	1.33 m (4 ft. 4 in.)
K	Fork Height, Maximum Reach	1.47 m (4 ft. 10 in.)
L	Reach, Ground Level	830 mm (33 in.)
M	Tine Length	1.22 m (48 in.)
N	Load Position, 50% Tine Length	0.61 m (24 in.)

Specifications with Fork As measured with fork level, centered on tine

Tipping Load, Straight	3170 kg (6,989 lb.)
Tipping Load, 40-deg. Full Turn	1902 kg (4,193 lb.)
Rated Operating Load, 50% Full-Turn Tipping Load (conforms to ISO 14397-1 and SAE J1197)*	951 kg (2,097 lb.)
Rated Operating Load, Rough Terrain, 60% Full-Turn Tipping Load (conforms to EN474-3)*	1141 kg (2,516 lb.)
Rated Operating Load, Firm and Level Ground, 80% Full-Turn Tipping Load (conforms to EN474-3)*	1522 kg (3,355 lb.)

*Rated operating capacity based on Deere attachments only.

Bucket Selection Guide*

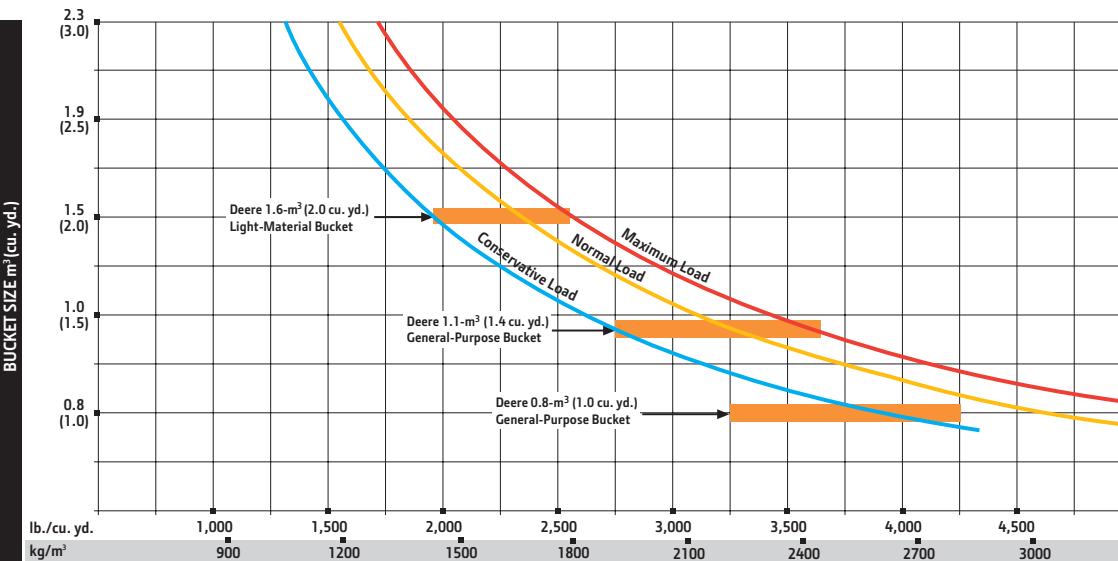

LOOSE MATERIALS	kg/m³ lb./cu. yd.	
Chips, pulpwood	288	486
Cinders (coal, ashes, clinkers)	673	1,134
Clay and gravel, dry	1602	2,700
Clay, compact, solid	1746	2,943
Clay, dry in lump loose	1009	1,701
Clay, excavated in water	1282	2,160
Coal, anthracite, broken, loose	865	1,458
Coal, bituminous, moderately wet	801	1,350
Earth, common loam, dry	1218	2,052
Earth, mud, packed	1843	3,105
Granite, broken	1538	2,592
Gypsum	2275	3,834
Limestone, coarse, sized	1570	2,646
Limestone, mixed sizes	1682	2,835
Limestone, pulverized or crushed	1362	2,295
Sand, damp	2083	3,510
Sand, dry	1762	2,970
Sand, voids, full of water	2083	3,510
Sandstone, quarried	1314	2,214
Shale, broken crushed	1362	2,295
Slag, furnace granulated	1955	3,294
Stone or gravel, 37.5 to 87.5-mm (1.5 to 3.5") size	1442	2,430
Stone or gravel, 18.75-mm (3/4") size	1602	2,700

*This guide, representing bucket sizes not necessarily manufactured by Deere, will help you in selecting proper bucket size for material density, loader configuration, and operating conditions. Optimum bucket size is determined after adding or subtracting all tipping load changes due to optional equipment. The "conservative load" line on this guide is recommended when operating in conditions such as soft ground and unlevel surfaces. The "maximum load" condition on this guide is sometimes utilized when operating on firm ground and level surfaces.

Additional equipment

Key: ● Standard ▲ Optional or special

*See your John Deere dealer for further information.

204K	304K	Engine
●	●	Meets EPA Interim Tier 4/EU Stage IIIA emissions
●	●	Antifreeze, -37 deg. C (-34 deg. F)
●	●	Coolant recovery tank
●	●	Fan safety guard
●	●	Fan, sucker type, direct drive
●	●	Muffler, under hood, with curved end exhaust stack
●	●	Environmentally friendly engine oil drain
●	●	Engine oil cooler
●	●	Quick-release fuel filter and water separator
●	●	Automatic engine air preheater for cold start
▲	▲	Engine coolant heater, 1,000 watts, 110 volts
		Electrical
●	●	Starter switch with electric fuel cutoff
●	●	12-volt system
●	●	Electrical load center: Blade-type fuses
●	●	Standard battery (1), 12 volt with 850 CCA, 80-min. reserve
●	●	Master electrical disconnect switch
●	●	Alternator, 12 volts, 80 amps
●	●	Horn (conforms to SAE J994 / J1446)
●	●	Lights (conform to SAE 99): Driving / Turn signals / Flashers / Stop / Taillights
●	●	Worklights, front (2)
●	●	Worklights, rear (2)
●	●	Reverse warning alarm (conforms to SAE J994 / J1446)
●	●	Multifunction monitor with audible and visual warnings: Engine coolant temperature and hydraulic oil temperature / Gauge: Fuel / Visual indicators: Air-filter restriction, low voltage, coolant temperature, engine oil pressure, engine pre-heat, hydraulic oil temperature, lights high beam, park brake, turn signals, fuel-level gauge, and hour meter

204K	304K	Electrical (continued)
●	●	Indicator lights: Engine air filter/ Battery voltage / Parking brake actuated / Forward/reverse travel / 1st- or 2nd-speed range / Turn signal and hazard lights / High-beam driving lights
●	●	Radio-ready cab, fused 12-volt radio electrical lead and speakers, power port
●	●	Pre-wired for roof beacon
		Powertrain/Brakes
●	●	Hydrostatic (HST) transmission: Electric shift control / Single-lever joystick F-N-R / Hydrostatic oil cooler / Inching pedal / 2 speeds forward and reverse / Infinitely variable speed control
●	●	Parking brake, spring applied, hydraulically released, switch operated
●	●	Limited-slip differential, 45% front and rear
		Hydraulic System
●	●	Hydraulic system oil cooler
●	●	Visual-indicator bucket return-to-dig control
●	●	Float detent
●	●	Reservoir sight gauge
●	●	Fine-micron hydraulic filters, vertical mounting
●	●	Hydraulic function lockout
▲	▲	3-function hydraulic valve with joystick control and manual auxiliary lever for 3rd function
●	●	Quick-coupler diagnostic ports: Priority pressure / Hydraulic pump pressure / Control valve pressure / HST pressure
		Operator's Station
▲	▲	Cab (conforms to SAE J1040, SAE J231, ISO 3471, and ISO 3449): Air conditioner/heater/defroster / Tilt steering / Inside mirror
●	●	Canopy
●	●	Storage compartment for operator's manual and other items

204K	304K	Operator's Station (continued)
●	●	Rubber floor mat
●	●	Rearview mirrors, outside (2)
●	●	Handholds and steps, ergonomically located and slip resistant (conform to SAE J185)
		Loader Linkage
●	●	Z-bar loader linkage provides high bucket breakout
●	●	Loader boom service locking bar (conforms to SAE J38)
		Buckets and Attachments
▲	▲	Full line of buckets with selection of bolt-on cutting edges
▲	▲	Electrically actuated quick-coupler with flags
▲	▲	Full line of construction utility forks, pallet forks, extendable booms with hook, and other attachments*
		Tires
●	●	365/70R18 Dunlop SPT9
▲	▲	365/70R18 Mitas EM-01
▲	▲	400/70R20 Michelin XMCL
●	●	405/70R18 Dunlop SPT9
▲	▲	405/70R18 Firestone DuraForce
▲	▲	405/70R20 Mitas EM-01
		Other
●	●	Fenders, front and rear
●	●	Articulation locking bar (conforms to SAE J276)
●	●	Vandal protection, includes lockable engine enclosure
●	●	Counterweight, saddle-type, built-in
●	●	Rear bottom guard, built-in
●	●	Drawbar, with locking pin
●	●	Lift eyes
●	●	Tie-downs
▲	▲	Fire extinguisher
▲	▲	Material-weighing system*
▲	▲	JDLink™ wireless communication system (available in specific countries; see your dealer for details)



Net engine power is with standard equipment including air cleaner, exhaust system, alternator, and cooling fan, at test conditions specified per ISO 9249. No derating is required up to 3000-m (10,000 ft.) altitude. Specifications and design subject to change without notice. Wherever applicable, specifications are in accordance with SAE standards. Except where otherwise noted, these specifications are based on a unit with all standard equipment, ROPS cab, standard rear counterweight, full fuel tank, and 79-kg (175 lb.) operator; 204K unit with 365/70R18 tires; and 304K unit with 405/70R18 Dunlop SPT9 tires.

www.JohnDeere.com