



Building a better world around you

- Small in size
- Big in lifting power
- Versatile hydraulic quick change attachments
- Easy to operate
- Reliable / Durable
- Service and maintenance ease
- Operator friendly environment
- Low operating cost
- Customer support

- Perkins diesel engine24.8 hp
- Bucket capacity5 cu. yd
- Operating weight 3,240 lbs

C170B

WHEEL LOADER



Sales • Service • Parts

Distributed by:

When Your Business Depends
On The Right Choice,
The Right Choice is “Coyote!”

COYOTE C170B

Hydrostatic Drive Wheel Loader: Powerful • Silent • Economical

■ Engine

Make: Perkins diesel
 Type: 403D-11
 Output: 24.8 hp
 # of cylinders: 3
 Dry-type air cleaner with electric display.

■ Undercarriage

Rear axle oscillation, $\pm 12.5^\circ$
 Axles with planetary reduction gears in wheel hubs.
 Self locking differentials

■ Electrical System

Operating Voltage: 12 V
 Battery: 1 x 12 V, 100 Ah
 Alternator: 600 W
 Starter: 12 V

■ Operating Data (Bucket)

Standard Bucket Capacity: .50 cu yd
 Bucket Width: 4 ft 9 in
 Width Over Tires: 3 ft 4 in.
 Breakout Force: 1102 lbs.
 Service Weight: 3,240 lbs.

■ Transmission

Hydrostatic drive with automotive-type variable speed control.
 Automatic torque output variation to meet operating demands.
 Work speed range: 0 – 4 mph.
 Travel speed range: 0 – 7 mph.

■ Tires

Low pressure tires 27x8.5-15
 Wide tires 26x12-12

■ Loading Equipment

Kinematics for high breakout force, fast dumping, parallel action, automatic bucket return to dig position.

Single lever for easy control.
 Float position. 3rd control circuit.

■ Brakes

Disc brakes on the rear axle.

■ Steering

Center point frame articulation
 Front and rear wheels follow the same track.
 Load sensing hydraulic system.
 Steering angle 34° to either side.

■ Hydraulic System

Gear type pump for loading and steering hydraulics, two lifting cylinders and one tilting cylinder.
 Operating pressure: 2,320 psi.

■ Standard Equipment

Rapid changeover system, hydraulic.
 Rear-view mirrors on both sides.
 Deluxe driver's seat with safety belt.
 3rd control circuit
 Reversing lights

■ Optional Equipment

Pallet fork
 General purpose buckets
 Additional attachments available.

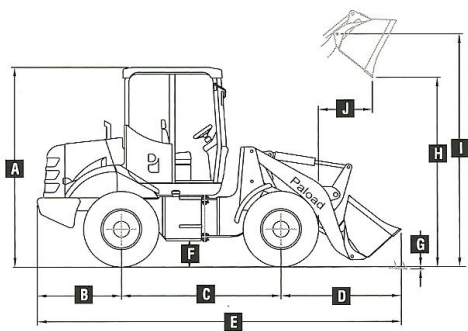

A	7'5"
B	2'6"
C	4'6"
D	4'10"
E	12'1"
F	8"
G	2"
H	6'6"
I	7'5"
J	1'9"

* Information herein is not warranted and subject to change without notice. Coyote Loaders or its agents will not assume any liability for errors.